

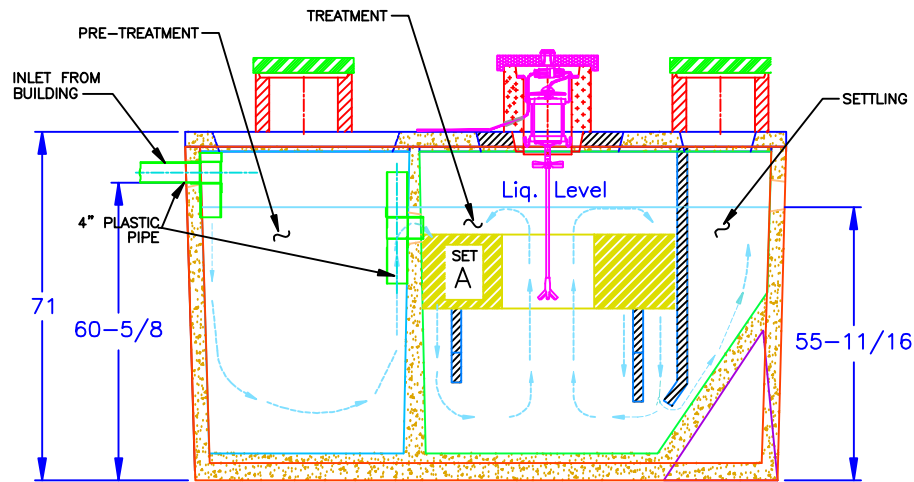

**NOTES:**

- 1.) AERATOR MODEL 700LL MUST BE USED IN CONTINUOUS OPERATION.
- 2.) IF AERATOR MOUNTING CASTING HAS NO RISER, RISERS ARE NOT REQUIRED HERE. REMOVABLE CONCRETE COVERS, OR PLASTIC COVERS SECURED WITH TAMPER RESISTANT FASTNERS ARE REQUIRED.
- 3.) IF AERATOR MOUNTING CASTING HAS A RISER(S), COVERED RISERS ARE REQUIRED HERE. RISERS SHOULD BE DEVELOPED TO GRADE OR TO 6"-12" BELOW GRADE.

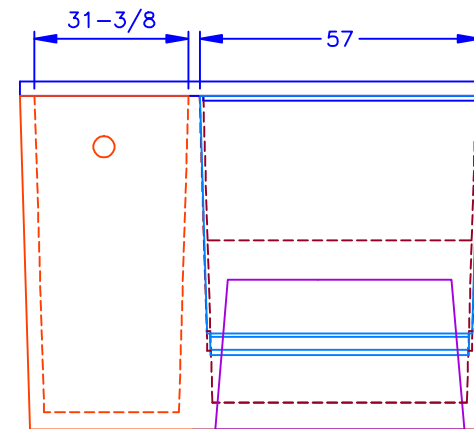

TANK AND LID ASSEMBLY

ITEM	REV'D	PART NO.	DESCRIPTION
I	H	G	F E D C B A
			REV. EX NO. DATE
			DRAWN BY: SSZ DATE: 04-10-08 APPROVED BY: TML DATE: 07-15-08 MATERIAL:
TITLE: J-500 TANK WITH ATTACHED 750 PUMP TANK			SCALE:
USED ON: C			UNLESS OTHERWISE SPECIFIED: ALL DIMENSIONS IN INCHES DECIMAL: ± .005 FRACTION: ± 1/64 DEGREE: ± 1°
<small>Confidential and Proprietary Property of Jet, Inc. - No part of this drawing may be published, reproduced, copied, or used in any form, without the prior written permission of Jet, Inc.</small>			DRAWING NUMBER: <b>J-500-P750</b>